

# MS-98D7

***COM Express Compact Module***



## Copyright Notice

The material in this document is the intellectual property of **MICRO-STAR INTERNATIONAL**. We take every care in the preparation of this document, but no guarantee is given as to the correctness of its contents. Our products are under continual improvement and we reserve the right to make changes without notice.

## Trademarks

All trademarks are the properties of their respective owners.

- MSI® is a registered trademark of Micro-Star Int'l Co., Ltd.
- NVIDIA® is a registered trademark of NVIDIA Corporation.
- AMD® is a registered trademark of AMD Corporation.
- Intel® is a registered trademark of Intel Corporation.
- Windows® is a registered trademark of Microsoft Corporation.
- AMI® is a registered trademark of Advanced Micro Devices, Inc.
- Award® is a registered trademark of Phoenix Technologies Ltd.
- Realtek® is a registered trademark of Realtek Semiconductor Corporation.

## Revision History

Revision	Date
V1.0	2014/05

## Technical Support

If a problem arises with your system and no solution can be obtained from the user's manual, please contact your place of purchase or local distributor. Alternatively, please try the following help resources for further guidance.



Visit the MSI website for technical guide, BIOS updates, driver updates, and other information:  
<http://www.msi.com/service/download/>



Contact our technical staff at:  
<http://support.msi.com/>

# Safety Instructions

- Always read the safety instructions carefully.
- Keep this User's Manual for future reference.
- Keep this equipment away from humidity.
- Lay this equipment on a reliable flat surface before setting it up.
- The openings on the enclosure are for air convection hence protects the equipment from overheating. **DO NOT COVER THE OPENINGS.**
- Make sure the voltage of the power source and adjust properly 110/220V before connecting the equipment to the power inlet.
- Place the power cord such a way that people can not step on it. Do not place anything over the power cord.
- Always Unplug the Power Cord before inserting any add-on card or module.
- All cautions and warnings on the equipment should be noted.
- Never pour any liquid into the opening that could damage or cause electrical shock.
- If any of the following situations arises, get the equipment checked by service personnel:
  - The power cord or plug is damaged.
  - Liquid has penetrated into the equipment.
  - The equipment has been exposed to moisture.
  - The equipment does not work well or you can not get it work according to User's Manual.
  - The equipment has dropped and damaged.
  - The equipment has obvious sign of breakage.
- **DO NOT LEAVE THIS EQUIPMENT IN AN ENVIRONMENT UNCONDITIONED, STORAGE TEMPERATURE ABOVE 60°C (140°F), IT MAY DAMAGE THE EQUIPMENT.**

## 警告使用者:

這是甲類資訊產品，在居住的環境中使用時，可能會造成無線電干擾，在這種情況下，使用者會被要求採取某些適當的對策。

## Chemical Substances Information

In compliance with chemical substances regulations, such as the EU REACH Regulation (Regulation EC No. 1907/2006 of the European Parliament and the Council), MSI provides the information of chemical substances in products at:

[http://www.msi.com/html/popup/csr/evmtprrt\\_pcm.html](http://www.msi.com/html/popup/csr/evmtprrt_pcm.html)

## Battery Information

---



European Union:

Batteries, battery packs, and accumulators should not be disposed of as unsorted household waste. Please use the public collection system to return, recycle, or treat them in compliance with the local regulations.

---



Taiwan:

For better environmental protection, waste batteries should be collected separately for recycling or special disposal.

---

廢電池請回收

---

California, USA:

The button cell battery may contain perchlorate material and requires special handling when recycled or disposed of in California.

For further information please visit:

<http://www.dtsc.ca.gov/hazardouswaste/perchlorate/>

---

Danger of explosion if battery is incorrectly replaced. Replace only with the same or equivalent type recommended by the manufacturer.

---

## CE Conformity

Hereby, Micro-Star International CO., LTD declares that this device is in compliance with the essential safety requirements and other relevant provisions set out in the European Directive.



## FCC-A Radio Frequency Interference Statement



This equipment has been tested and found to comply with the limits for a Class A digital device, pursuant to Part 15 of the FCC Rules. These limits are designed to provide reasonable protection against harmful interference when the equipment is operated in a commercial environment. This equipment generates, uses and can radiate radio frequency energy and, if not installed and used in accordance with the instruction manual, may cause harmful interference to radio communications. Operation of this equipment in a residential area is likely to cause harmful interference, in which case the user will be required to correct the interference at his own expense.

### Notice 1

The changes or modifications not expressly approved by the party responsible for compliance could void the user's authority to operate the equipment.

### Notice 2

Shielded interface cables and AC power cord, if any, must be used in order to comply with the emission limits.

### VOIR LA NOTICE D'INSTALLATION AVANT DE RACCORDER AU RESEAU.

This device complies with Part 15 of the FCC Rules. Operation is subject to the following two conditions:

- 1) this device may not cause harmful interference, and
- 2) this device must accept any interference received, including interference that may cause undesired operation.

## WEEE Statement

Under the European Union ("EU") Directive on Waste Electrical and Electronic Equipment, Directive 2002/96/EC, which takes effect on August 13, 2005, products of "electrical and electronic equipment" cannot be discarded as municipal waste anymore and manufacturers of covered electronic equipment will be obligated to take back such products at the end of their useful life. MSI will comply with the product take back requirements at the end of life of MSI-branded products that are sold into the EU. You can return these products to local collection points.



# CONTENTS

Copyright Notice.....	ii
Trademarks .....	ii
Revision History .....	ii
Technical Support.....	ii
Safety Instructions.....	iii
Chemical Substances Information .....	iv
Battery Information .....	iv
CE Conformity.....	v
FCC-A Radio Frequency Interference Statement .....	v
WEEE Statement .....	v
<b>1. Overview.....</b>	<b>1-1</b>
Specifications .....	1-2
Layout .....	1-4
Block Diagram.....	1-5
<b>2. Hardware Setup .....</b>	<b>2-1</b>
Memory .....	2-3
Connector.....	2-4
Hardware Installation .....	2-10
<b>3. BIOS Setup.....</b>	<b>3-1</b>
Entering Setup .....	3-2
The Menu Bar .....	3-4
Main .....	3-5
Advanced .....	3-6
Boot.....	3-13
Security .....	3-14
Chipset .....	3-19
Power .....	3-21
Save & Exit.....	3-23

# 1 Overview

Thank you for choosing the MS-98D7, an excellent COM (computer-on-module) Express Compact Module. Integrating core CPU and memory functionality, it is the entry-level model for applications looking to transition from other small form factor solutions to COM Express® and offers full PCI Express, USB, SATA, audio, graphics and network support.

# Specifications

## Processor (Optional)

- Intel Embedded Mobile Core i7/ i5/ i3/ Celeron Processor
  - Core i7-3615QE/ i7-3612QE/ i7-3555LE/ i7-3517UE
  - Core i5-3610ME
  - Core i3-3120ME/ i3-3217UE
  - Celeron

## Chipset

- Intel QM77 chipset

## Memory

- 1 DDR3/DDR3L 1066/1333/1600 MHz SO-DIMM slot
- Supports non-ECC, unbuffered DDR3/DDR3L SO-DIMMs only
- Supports the maximum of 8GB

## LAN

- PCH Integrated Gigabit LAN controller
- Intel 82579LM Gigabit Fast Ethernet controller

## Graphics

- Graphics integrated in Intel processor

## EC

- IT 8518 controller chip providing all PC-compatible I/O

## SATA

- Supports 4 Serial ATA interfaces
  - 2 SATA 6Gb/s ports, 2 SATA 3Gb/s ports
  - Integrated Advanced Host Controller Interface (AHCI) controller

## USB

- Supports 8 internal Universal Serial Bus (USB) ports (including one for Mini PCIe card)
  - USB 3.0\_Port 0, 1, 2, 3
  - USB 2.0\_Port 0, 1, 2, 3, 4, 5, 6, 7

## Digital Display Interface (DDI)

- HDMI
- DVI
- DisplayPort



### **PCI Express Interface**

- PCIe x1
- PCIe x16

### **Form Factor**

- COM Express Compact: 95mm x 95mm

### **Environmental**

- Operating Temperature: 0°C ~ 60°C
- Storage Temperature: -20°C ~ 80°C
- Humidity: 5% ~ 90% RH, Non-Condensing

# Layout

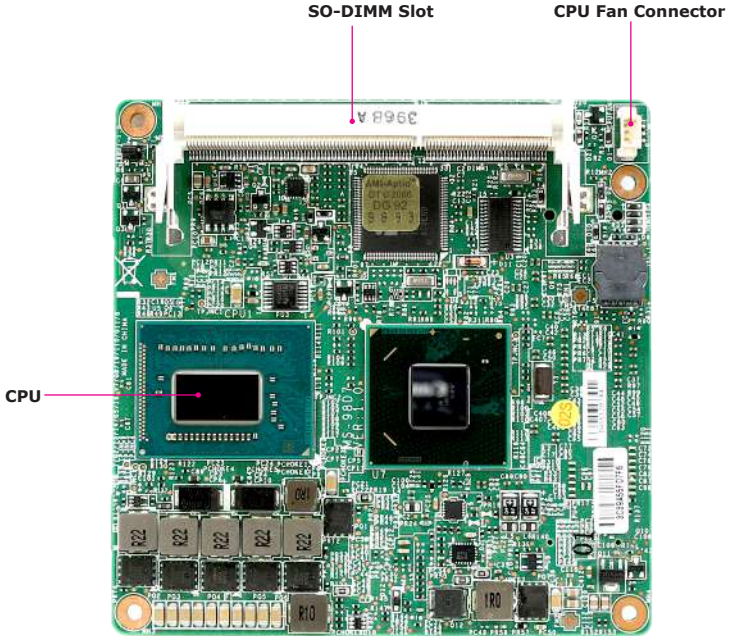

# Block Diagram

## Com Express Type 6

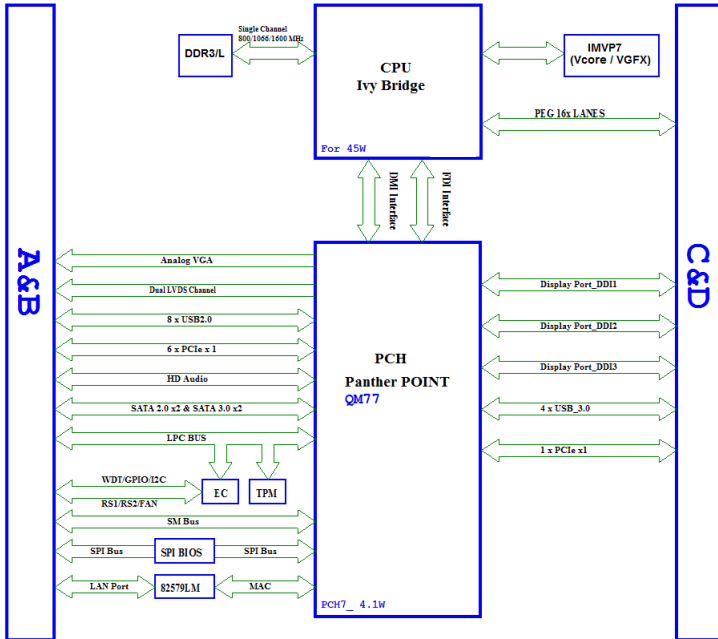

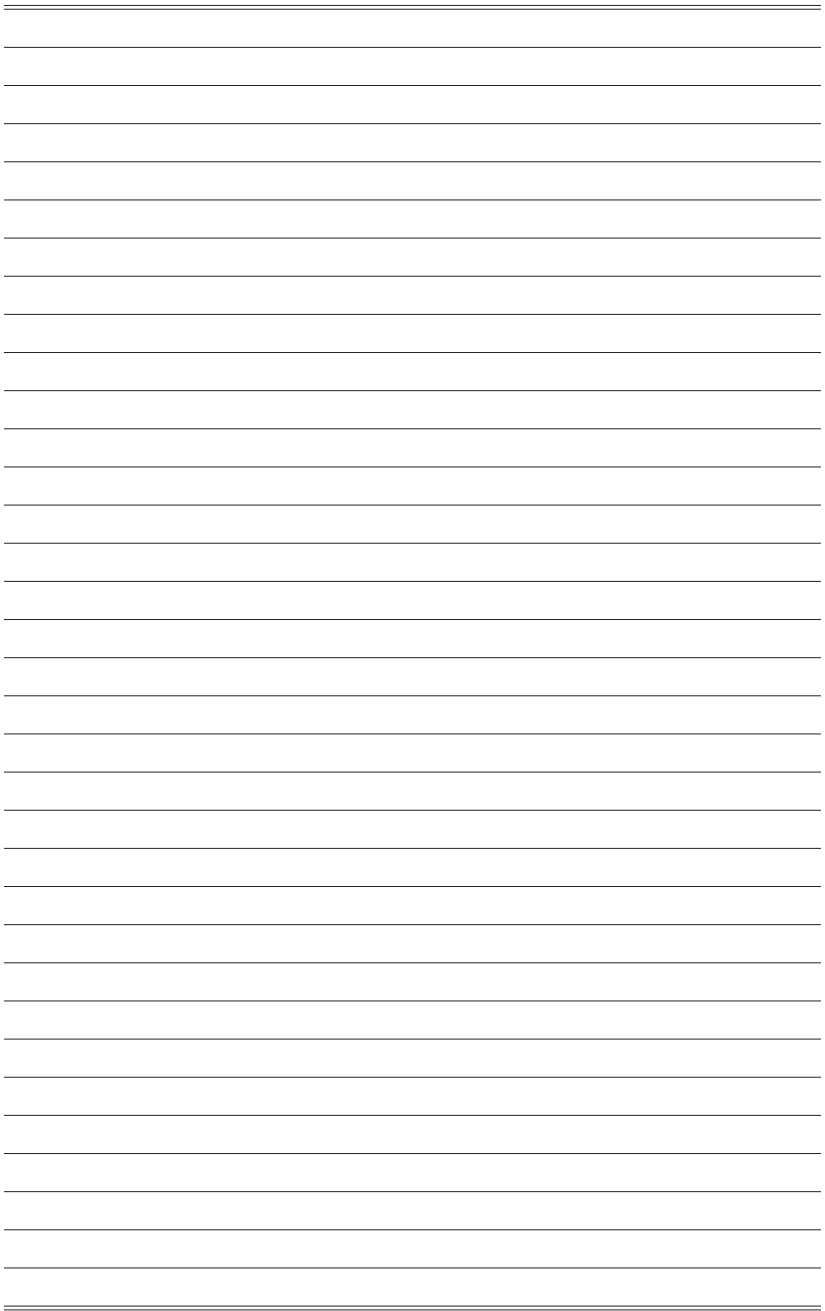

# 2 Hardware Setup

This chapter provides you with the information about hardware setup procedures. While doing the installation, be careful in holding the components and follow the installation procedures. For some components, if you install in the wrong orientation, the components will not work properly.

Use a grounded wrist strap before handling computer components. Static electricity may damage the components.

# Components Reference Guide

<b>Memory</b> .....	<b>2-3</b>
<b>Connector</b> .....	<b>2-4</b>
Fan Power Connector: CPUFAN1.....	2-4
COM Express Connectors .....	2-5

# Memory

The SO-DIMM slot is intended for memory modules.

1. Locate the SO-DIMM slot. Align the notch on the DIMM with the key on the slot and insert the DIMM into the slot.

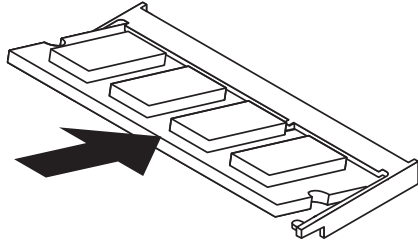

2. Push the DIMM gently downwards until the slot levers click and lock the DIMM in place.

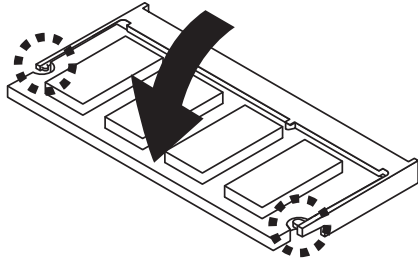

3. To uninstall the DIMM, flip the slot levers outwards and the DIMM will be released instantly.

## **Important**

*You can barely see the golden finger if the DIMM is properly inserted in the DIMM slot.*

# Connector

## Fan Power Connector: CPUFAN1

The fan power connectors support system cooling fan with +12V. When connecting the wire to the connectors, always note that the red wire is the positive and should be connected to the +12V; the black wire is Ground and should be connected to GND. If the motherboard has a System Hardware Monitor chipset onboard, you must use a specially designed fan with speed sensor to take advantage of the CPU fan control.

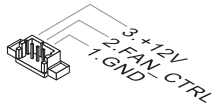

### **Important!**

*Please refer to the recommended CPU fans at processor's official website or consult the vendors for proper CPU cooling fan.*



## COM Express Connectors

The COM Express connectors are used to interface the COM Express module board to a carrier board. Connect the COM Express connectors located on the solder side of the module board (as indicated below) to the COM Express connectors on the carrier board.

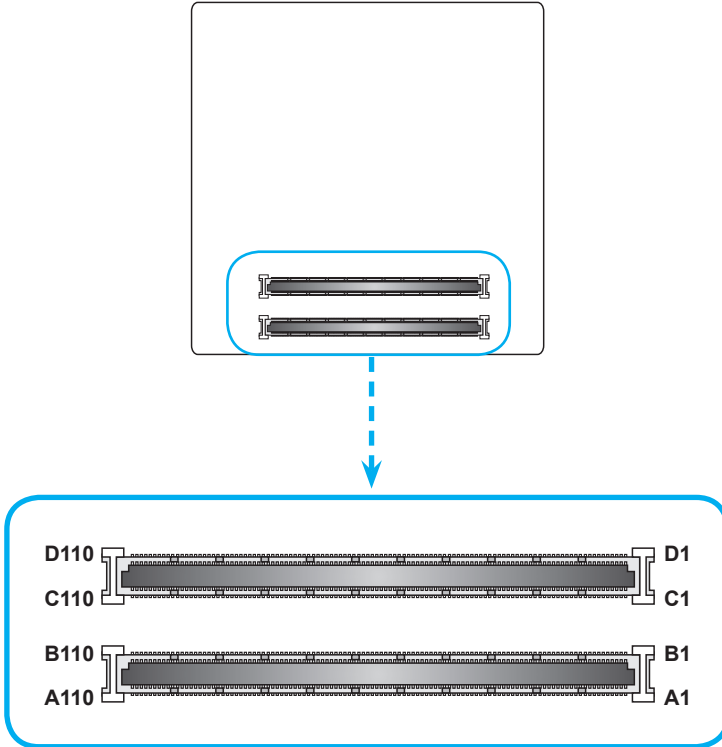

Row A		Row B		Row C		Row D	
A1	GND (FIXED)	B1	GND (FIXED)	C1	GND (FIXED)	D1	GND (FIXED)
A2	GBE0_MDI3-	B2	GBE0_ACT#	C2	GND	D2	GND
A3	GBE0_MDI3+	B3	LPC_FRAME#	C3	USB_SSRX0-	D3	USB_SSTX0-
A4	G B E 0 _ LINK100#	B4	LPC_AD0	C4	USB_SSRX0+	D4	USB_SSTX0+
A5	G B E 0 _ LINK1000#	B5	LPC_AD1	C5	GND	D5	GND
A6	GBE0_MDI2-	B6	LPC_AD2	C6	USB_SSRX1-	D6	USB_SSTX1-
A7	GBE0_MDI2+	B7	LPC_AD3	C7	USB_SSRX1+	D7	USB_SSTX1+
A8	GBE0_LINK#	B8	LPC_DRQ0#	C8	GND	D8	GND
A9	GBE0_MDI1-	B9	LPC_DRQ1#	C9	USB_SSRX2-	D9	USB_SSTX2-
A10	GBE0_MDI1+	B10	LPC_CLK	C10	USB_SSRX2+	D10	USB_SSTX2+
A11	GND (FIXED)	B11	GND (FIXED)	C11	GND (FIXED)	D11	GND (FIXED)
A12	GBE0_MDI0-	B12	PWRBTN#	C12	USB_SSRX3-	D12	USB_SSTX3-
A13	GBE0_MDI0+	B13	SMB_CK	C13	USB_SSRX3+	D13	USB_SSTX3+
A14	GBE0_CTREF	B14	SMB_DAT	C14	GND	D14	GND
A15	SUS_S3#	B15	SMB_ALERT#	C15	DDI1_PAIR6+	D15	DDI1_CTRL- CLK_AUX+
A16	SATA0_TX+	B16	SATA1_TX+	C16	DDI1_PAIR6-	D16	DDI1_CTRL- DATA_AUX-
A17	SATA0_TX-	B17	SATA1_TX-	C17	RSVD	D17	RSVD
A18	SUS_S4#	B18	SUS_STAT#	C18	RSVD	D18	RSVD
A19	SATA0_RX+	B19	SATA1_RX+	C19	PCIE_RX6+	D19	PCIE_TX6+
A20	SATA0_RX-	B20	SATA1_RX-	C20	PCIE_RX6-	D20	PCIE_TX6-
A21	GND (FIXED)	B21	GND (FIXED)	C21	GND (FIXED)	D21	GND (FIXED)
A22	SATA2_TX+	B22	SATA3_TX+	C22	PCIE_RX7+	D22	PCIE_TX7+
A23	SATA2_TX-	B23	SATA3_TX-	C23	PCIE_RX7-	D23	PCIE_TX7-
A24	SUS_S5#	B24	PWR_OK	C24	DDI1_HPDP	D24	RSVD
A25	SATA2_RX+	B25	SATA3_RX+	C25	DDI1_PAIR4+	D25	RSVD
A26	SATA2_RX-	B26	SATA3_RX-	C26	DDI1_PAIR4-	D26	DDI1_PAIR0+
A27	BATLOW#	B27	WDT	C27	RSVD	D27	DDI1_PAIR0-
A28	ATA_ACT#	B28	AC_SDIN2	C28	RSVD	D28	RSVD
A29	AC_SYNC	B29	AC_SDIN1	C29	DDI1_PAIR5+	D29	DDI1_PAIR1+
A30	AC_RST#	B30	AC_SDIN0	C30	DDI1_PAIR5-	D30	DDI1_PAIR1-
A31	GND (FIXED)	B31	GND (FIXED)	C31	GND (FIXED)	D31	GND (FIXED)
A32	AC_BITCLK	B32	SPKR	C32	DDI2_CTRL- CLK_AUX+	D32	DDI1_PAIR2+
A33	AC_SDOUT	B33	I2C_CK	C33	DDI2_CTRL- DATA_AUX-	D33	DDI1_PAIR2-
A34	BIOS_DIS0#	B34	I2C_DAT	C34	DDI2_DDC_ AUX_SEL	D34	DDI1_DDC_ AUX_SEL

A35	THRMTRIP#	B35	THRM#	C35	RSVD	D35	RSVD
A36	USB6-	B36	USB7-	C36	DDI3_CTRL- CLK_AUX+	D36	DDI1_PAIR3+
A37	USB6+	B37	USB7+	C37	DDI3_CTRL- DATA_AUX-	D37	DDI1_PAIR3-
A38	U S B _ 6 _ 7 _ OC#	B38	U S B _ 4 _ 5 _ OC#	C38	DDI3_DDC_ AUX_SEL	D38	RSVD
A39	USB4-	B39	USB5-	C39	DDI3_PAIR0+	D39	DDI2_PAIR0+
A40	USB4+	B40	USB5+	C40	DDI3_PAIR0-	D40	DDI2_PAIR0-
A41	GND (FIXED)	B41	GND (FIXED)	C41	GND (FIXED)	D41	GND (FIXED)
A42	USB2-	B42	USB3-	C42	DDI3_PAIR1+	D42	DDI2_PAIR1+
A43	USB2+	B43	USB3+	C43	DDI3_PAIR1-	D43	DDI2_PAIR1-
A44	U S B _ 2 _ 3 _ OC#	B44	U S B _ 0 _ 1 _ OC#	C44	DDI3_HPD	D44	DDI2_HPD
A45	USB0-	B45	USB1-	C45	RSVD	D45	RSVD
A46	USB0+	B46	USB1+	C46	DDI3_PAIR2+	D46	DDI2_PAIR2+
A47	VCC_RTC	B47	E X C D 1 _ PERST#	C47	DDI3_PAIR2-	D47	DDI2_PAIR2-
A48	E X C D 0 _ CPPE#	B48	E X C D 1 _ CPPE#	C48	RSVD	D48	RSVD
A49	E X C D 0 _ CPPE#	B49	SYS_RESET#	C49	DDI3_PAIR1-	D49	DDI2_PAIR3+
A50	LPC_SERIRQ	B50	CB_RESET#	C50	DDI3_PAIR3-	D50	DDI2_PAIR3-
A51	GND (FIXED)	B51	GND (FIXED)	C51	GND (FIXED)	D51	GND (FIXED)
A52	PCIE_TX5+	B52	PCIE_RX5+	C52	PEG_RX0+	D52	PEG_TX0+
A53	PCIE_TX5-	B53	PCIE_RX5-	C53	PEG_RX0-	D53	PEG_TX0-
A54	GPI0	B54	GPO1	C54	TYPE0#	D54	P E G _ L A N _ RV#
A55	PCIE_TX4+	B55	PCIE_RX4+	C55	PEG_RX1+	D55	PEG_TX1+
A56	PCIE_TX4-	B56	PCIE_RX4-	C56	PEG_RX1-	D56	PEG_TX1-
A57	GND	B57	GPO2	C57	TYPE1#	D57	TYPE2#
A58	PCIE_TX3+	B58	PCIE_RX3+	C58	PEG_RX2+	D58	PEG_TX2+
A59	PCIE_TX3-	B59	PCIE_RX3-	C59	PEG_RX2-	D59	PEG_TX2-
A60	GND (FIXED)	B60	GND (FIXED)	C60	GND (FIXED)	D60	GND (FIXED)
A61	PCIE_TX2+	B61	PCIE_RX2+	C61	PEG_RX3+	D61	PEG_TX3+
A62	PCIE_TX2-	B62	PCIE_RX2-	C62	PEG_RX3-	D62	PEG_TX3-
A63	GPI1	B63	GPO3	C63	RSVD	D63	RSVD
A64	PCIE_TX1+	B64	PCIE_RX1+	C64	RSVD	D64	RSVD
A65	PCIE_TX1-	B65	PCIE_RX1-	C65	PEG_RX4+	D65	PEG_TX4+
A66	GND	B66	WAKE0#	C66	PEG_RX4-	D66	PEG_TX4-
A67	GPI2	B67	WAKE1#	C67	RSVD	D67	GND
A68	PCIE_TX0+	B68	PCIE_RX0+	C68	PEG_RX5+	D68	PEG_TX5+

A69	PCIE_TX0-	B69	PCIE_RX0-	C69	PEG_RX5-	D69	PEG_TX5-
A70	GND (FIXED)	B70	GND (FIXED)	C70	GND (FIXED)	D70	GND (FIXED)
A71	LVDS_A0+	B71	LVDS_B0+	C71	PEG_RX6+	D71	PEG_TX6+
A72	LVDS_A0-	B72	LVDS_B0-	C72	PEG_RX6-	D72	PEG_TX6-
A73	LVDS_A1+	B73	LVDS_B1+	C73	GND	D73	GND
A74	LVDS_A1-	B74	LVDS_B1-	C74	PEG_RX7+	D74	PEG_TX7+
A75	LVDS_A2+	B75	LVDS_B2+	C75	PEG_RX7-	D75	PEG_TX7-
A76	LVDS_A2-	B76	LVDS_B2-	C76	GND	D76	GND
A77	LVDS_VDD_EN	B77	LVDS_B3+	C77	RSVD	D77	RSVD
A78	LVDS_A3+	B78	LVDS_B3-	C78	PEG_RX8+	D78	PEG_TX8+
A79	LVDS_A3-	B79	LVDS_BKLT_EN	C79	PEG_RX8-	D79	PEG_TX8-
A80	GND (FIXED)	B80	GND (FIXED)	C80	GND (FIXED)	D80	GND (FIXED)
A81	LVDS_A_CK+	B81	LVDS_B_CK+	C81	PEG_RX9+	D81	PEG_TX9+
A82	LVDS_A_CK-	B82	LVDS_B_CK-	C82	PEG_RX9-	D82	PEG_TX9-
A83	LVDS_I2C_CK	B83	LVDS_BKLT_CTRL	C83	RSVD	D83	RSVD
A84	LVDS_I2C_DAT	B84	VCC_5V_SBY	C84	GND	D84	GND
A85	GPI3	B85	VCC_5V_SBY	C85	PEG_RX10+	D85	PEG_TX10+
A86	KBD_RST#	B86	VCC_5V_SBY	C86	PEG_RX10-	D86	PEG_TX10-
A87	KBD_A20GATE	B87	VCC_5V_SBY	C87	GND	D87	GND
A88	PCIE0_CK_REF+	B88	BISO_DIS1#	C88	PEG_RX11+	D88	PEG_TX11+
A89	PCIE0_CK_REF-	B89	VGA_RED	C89	PEG_RX11-	D89	PEG_TX11-
A90	GND (FIXED)	B90	GND (FIXED)	C90	GND (FIXED)	D90	GND (FIXED)
A91	SPI_POWER	B91	VGA_GRN	C91	PEG_RX12+	D91	PEG_TX12+
A92	SPI_MISO	B92	VGA_BLU	C92	PEG_RX12-	D92	PEG_TX12-
A93	GPO0	B93	VGA_HSYNC	C93	GND	D93	GND
A94	SPI_CLK	B94	VGA_VSYNC	C94	PEG_RX13+	D94	PEG_TX13+
A95	SPI_MOSI	B95	VGA_I2C_CK	C95	PEG_RX13-	D95	PEG_TX13-
A96	GND	B96	VGA_I2C_DAT	C96	GND	D96	GND
A97	TYPE10#	B97	SPI_CS#	C97	RSVD	D97	RSVD
A98	RSVD	B98	RSVD	C98	PEG_RX14+	D98	PEG_TX14+
A99	RSVD	B99	RSVD	C99	PEG_RX14-	D99	PEG_TX14-
A100	GND (FIXED)	B100	GND (FIXED)	C100	GND (FIXED)	D100	GND (FIXED)
A101	RSVD	B101	RSVD	C101	PEG_RX15+	D101	PEG_TX15+
A102	RSVD	B102	RSVD	C102	PEG_RX15-	D102	PEG_TX15-
A103	RSVD	B103	RSVD	C103	GND	D103	GND

A104	VCC_12V	B104	VCC_12V	C104	VCC_12V	D104	VCC_12V
A105	VCC_12V	B105	VCC_12V	C105	VCC_12V	D105	VCC_12V
A106	VCC_12V	B106	VCC_12V	C106	VCC_12V	D106	VCC_12V
A107	VCC_12V	B107	VCC_12V	C107	VCC_12V	D107	VCC_12V
A108	VCC_12V	B108	VCC_12V	C108	VCC_12V	D108	VCC_12V
A109	VCC_12V	B109	VCC_12V	C109	VCC_12V	D109	VCC_12V
A110	GND (FIXED)	B110	GND (FIXED)	C110	GND (FIXED)	D110	GND (FIXED)

# Hardware Installation

## ► Installing Module Board onto Carrier Board

### **Important**

*The illustrations are provided to guide users on how to install the module board onto the carrier board of their choice and should be held for reference only.*

1. Locate the threaded standoffs on the carrier board.

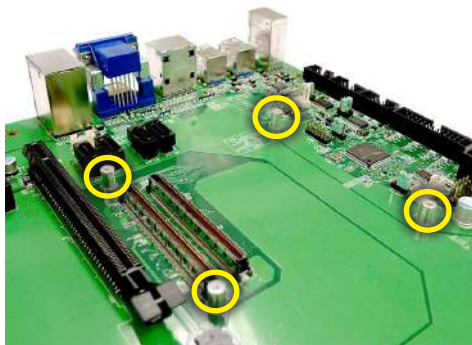

2. Position the module board on top of the carrier board with its mounting holes aligned with the standoffs on the carrier board and the COM Express connectors of both boards aligned to each other. Press the module board down firmly until it is securely seated on the COM Express connectors of the carrier board.



3. Locate the cooler and remove the plastic covering from its thermal pads.

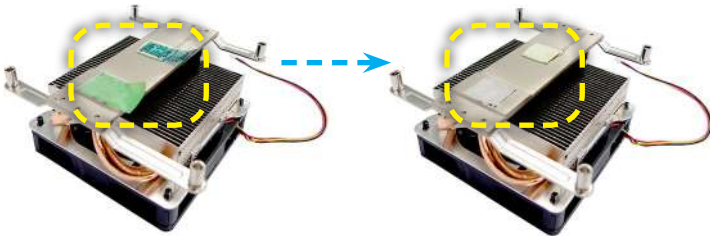

4. Mount the cooler onto the module board with mounting holes aligned.



5. Use the provided mounting screws to secure the cooler to the module board and the carrier board.

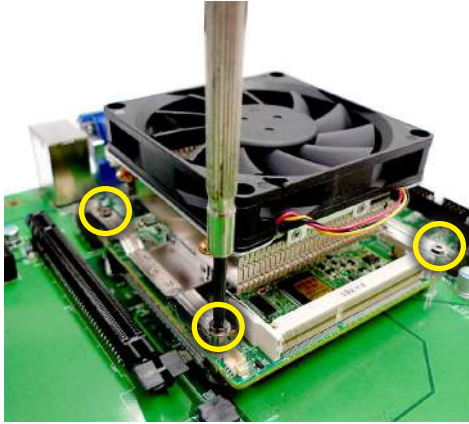

6. Finally, attach the cooler cable to the CPU fan connector on the module board.





# 3 BIOS Setup

This chapter provides information on the BIOS Setup program and allows users to configure the system for optimal use.

Users may need to run the Setup program when:

- An error message appears on the screen at system startup and requests users to run SETUP.
- Users want to change the default settings for customized features.

## **Important**

- *Please note that BIOS update assumes technician-level experience.*
- *As the system BIOS is under continuous update for better system performance, the illustrations in this chapter should be held for reference only.*

## Entering Setup

Power on the computer and the system will start POST (Power On Self Test) process. When the message below appears on the screen, press <DEL> key to enter Setup.

Press <DEL> to enter SETUP

If the message disappears before you respond and you still wish to enter Setup, restart the system by turning it OFF and On or pressing the RESET button. You may also restart the system by simultaneously pressing <Ctrl>, <Alt>, and <Delete> keys.

### **Important**

*The items under each BIOS category described in this chapter are under continuous update for better system performance. Therefore, the description may be slightly different from the latest BIOS and should be held for reference only.*

## Control Keys

← →	Select Screen
↑ ↓	Select Item
Enter	Select
+ -	Change Option
F1	General Help
F7	Previous Values
F9	Optimized Defaults
F10	Save & Exit
Esc	Exit

## Getting Help

After entering the Setup menu, the first menu you will see is the Main Menu.

### Main Menu

The main menu lists the setup functions you can make changes to. You can use the arrow keys ( ↑ ↓ ) to select the item. The on-line description of the highlighted setup function is displayed at the bottom of the screen.

### Sub-Menu

If you find a right pointer symbol appears to the left of certain fields that means a sub-menu can be launched from this field. A sub-menu contains additional options for a field parameter. You can use arrow keys ( ↑ ↓ ) to highlight the field and press <Enter> to call up the sub-menu. Then you can use the control keys to enter values and move from field to field within a sub-menu. If you want to return to the main menu, just press the <Esc >.

### General Help <F1>

The BIOS setup program provides a General Help screen. You can call up this screen from any menu by simply pressing <F1>. The Help screen lists the appropriate keys to use and the possible selections for the highlighted item. Press <Esc> to exit the Help screen.

# The Menu Bar

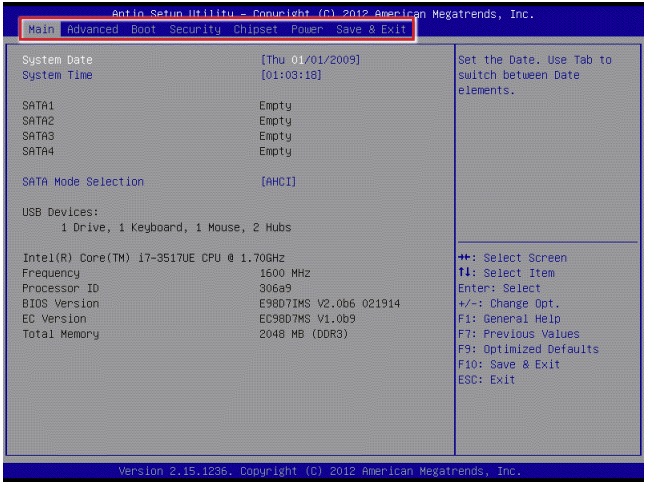

► **Main**

Use this menu for basic system configurations, such as time, date, etc.

► **Advanced**

Use this menu to set up the items of special enhanced features.

► **Boot**

Use this menu to specify the priority of boot devices.

► **Security**

Use this menu to set supervisor and user passwords.

► **Chipset**

This menu controls the advanced features of the onboard chipsets.

► **Power**

Use this menu to specify your settings for power management.

► **Save & Exit**

This menu allows you to load the BIOS default values or factory default settings into the BIOS and exit the BIOS setup utility with or without changes.

# Main

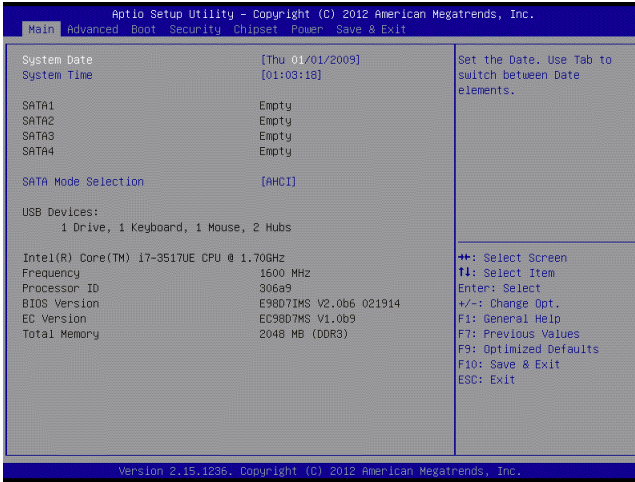

## ► System Date

This setting allows you to set the system date. The date format is <Day>, <Month> <Date> <Year>.

## ► System Time

This setting allows you to set the system time. The time format is <Hour> <Minute> <Second>.

## ► SATA Mode Selection

This setting specifies the SATA controller mode.

## Advanced

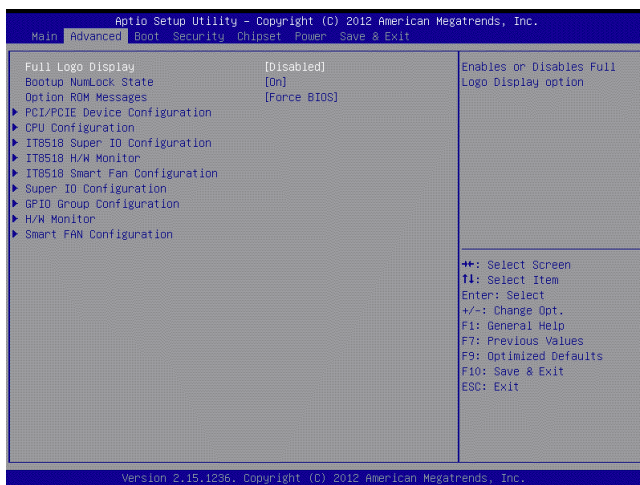

### ► Full Screen Logo Display

This BIOS feature determines if the BIOS should hide the normal POST messages with the motherboard or system manufacturer's full-screen logo.

When it is enabled, the BIOS will display the full-screen logo during the boot-up sequence, hiding normal POST messages.

When it is disabled, the BIOS will display the normal POST messages, instead of the full-screen logo.

Please note that enabling this BIOS feature often adds 2-3 seconds of delay to the booting sequence. This delay ensures that the logo is displayed for a sufficient amount of time. Therefore, it is recommended that you disable this BIOS feature for a faster boot-up time.

### ► Bootup NumLock State

This setting is to set the Num Lock status when the system is powered on. Setting to [On] will turn on the Num Lock key when the system is powered on. Setting to [Off] will allow users to use the arrow keys on the numeric keypad.

### ► Option ROM Messages

This item is used to determine the display mode when an optional ROM is initialized during POST. When set to [Force BIOS], the display mode used by AMI BIOS is used. Select [Keep Current] if you want to use the display mode of optional ROM.

## ► PCI/PCIE Device Configuration

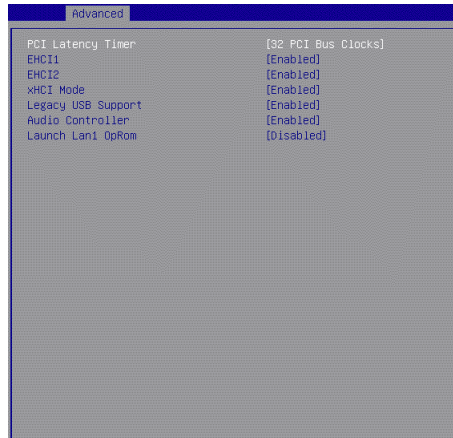

### ► PCI Latency Timer

This item controls how long each PCI device can hold the bus before another takes over. When set to higher values, every PCI device can conduct transactions for a longer time and thus improve the effective PCI bandwidth. For better PCI performance, you should set the item to higher values.

### ► EHCI1, EHCI2

This setting disables/enables the USB EHCI controller. The Enhanced Host Controller Interface (EHCI) specification describes the register-level interface for a Host Controller for the Universal Serial Bus (USB) Revision 2.0.

### ► XHCI Mode

This setting disables/enables the USB XHCI controller. The eXtensible Host Controller Interface (XHCI) is a computer interface specification that defines a register-level description of a Host Controller for Universal Serial bus (USB), which is capable of interfacing to USB 1.0, 2.0, and 3.0 compatible devices. The specification is also referred to as the USB 3.0 Host Controller specification.

### ► Legacy USB Support

Set to [Enabled] if you need to use any USB 1.1/2.0 device in the operating system that does not support or have any USB 1.1/2.0 driver installed, such as DOS and SCO Unix.

### ► Audio Controller

This setting enables/disables the onboard audio controller.

### ► Launch LAN1 OpROM

This setting enables/disables the initialization of the specified LAN Boot ROM during bootup. Selecting [Disabled] will speed up the boot process.

## ► CPU Configuration

Advanced	
CPU Configuration	
Intel(R) Core(TM) i7-3517UE CPU @ 1.70GHz	
CPU Signature	306a9
Microcode Patch	19
CPU Speed	1600 MHz
Processor Cores	2
Intel HT Technology	Supported
Intel VT-x Technology	Supported
Intel SMX Technology	Supported
64-bit	Supported
L2 Cache	256 kB x 2
L3 Cache	4096 kB
Hyper-threading	[Enabled]
Active Processor Cores	[All]
Execute Disable Bit	[Enabled]
Intel Virtualization Technology	[Disabled]
EIST	[Enabled]

### ► Hyper-Threading

The processor uses Hyper-Threading technology to increase transaction rates and reduces end-user response times. The technology treats the two cores inside the processor as two logical processors that can execute instructions simultaneously. In this way, the system performance is highly improved. If you disable the function, the processor will use only one core to execute the instructions. Please disable this item if your operating system doesn't support HT Function, or unreliability and instability may occur.

### ► Active Processor Cores

This setting specifies the number of active processor cores.

### ► Execute Disable Bit

Intel's Execute Disable Bit functionality can prevent certain classes of malicious "buffer overflow" attacks when combined with a supporting operating system. This functionality allows the processor to classify areas in memory by where application code can execute and where it cannot. When a malicious worm attempts to insert code in the buffer, the processor disables code execution, preventing damage or worm propagation.

### ► Intel Virtualization Technology

Virtualization enhanced by Intel Virtualization Technology will allow a platform to run multiple operating systems and applications in independent partitions. With virtualization, one computer system can function as multiple "Virtual" systems.

### ► EIST

EIST (Enhanced Intel SpeedStep Technology) allows the system to dynamically adjust processor voltage and core frequency, which can result in decreased average power consumption and decreased average heat production. When disabled, the processor will return the actual maximum CPUID input value of the processor when queried.



## ► IT8518 Super IO Configuration



### ► Watch Dog Timer

You can enable the system watch-dog timer, a hardware timer that generates a reset when the software that it monitors does not respond as expected each time the watch dog polls it.

### ► IT8518 H/W Monitor (*the Compact Module*)

These items display the current status of all monitored hardware devices/components such as voltages, temperatures and all fans' speeds.

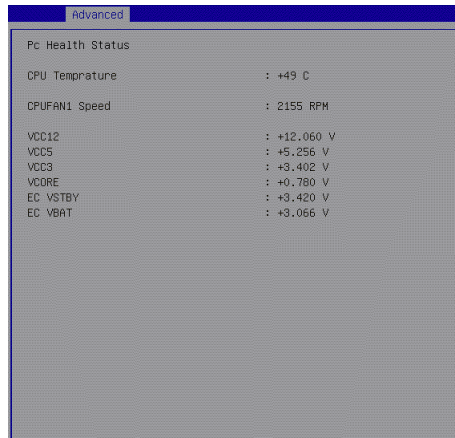

► **IT8518 Smart Fan Configuration** (*the Compact Module*)

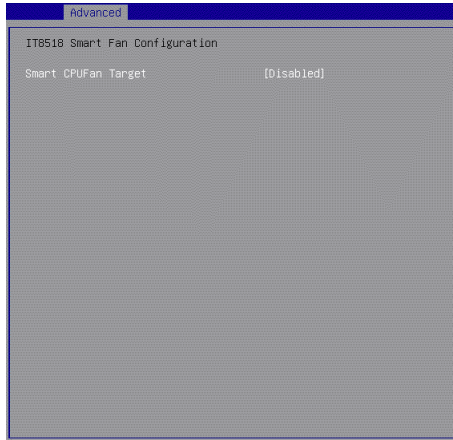

► **Smart CPUFAN Target**

These settings enable/disable the Smart Fan function. Smart Fan is an excellent feature which will adjust the CPU/system fan speed automatically depending on the current CPU/system temperature, avoiding the overheating to damage your system.

► **Super IO Configuration** (*the Carrier Board*)

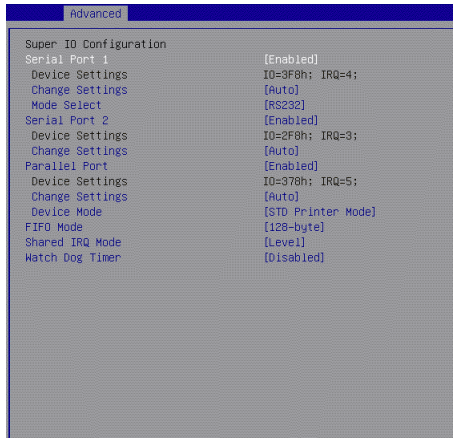

► **Serial Port 1, Serial Port 2**

This setting enables/disables the specified serial port.

► **Change Settings**

This setting is used to change the address & IRQ settings of the specified serial port.

► **Mode Select**

Select an operation mode for the serial port 1.

► **Parallel Port**

This setting enables/disables the parallel port.

► **Change Settings**

This setting is used to change the address & IRQ settings of the parallel port.

► **Device Mode**

Select an operation mode for the parallel port.

► **FIFO Mode**

This setting controls the FIFO data transfer mode.

► **Shared IRQ Mode**

This setting provides the system with the ability to share interrupts among its serial ports.

► **Watch Dog Timer**

You can enable the system watch-dog timer, a hardware timer that generates a reset when the software that it monitors does not respond as expected each time the watch dog polls it.

► **GPIO Group Configuration** (*the Carrier Board*)

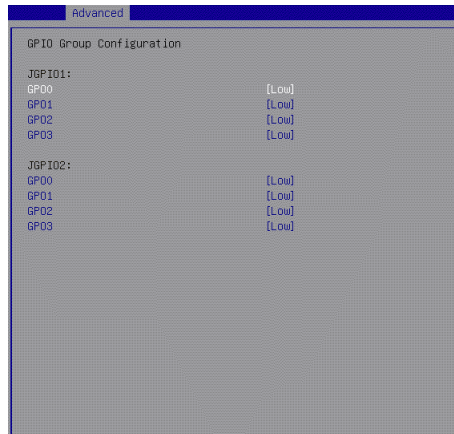

► **GPO0 ~ GPO3**

These settings control the operation mode of the specified GPIO.

► **H/W Monitor** *(the Carrier Board)*

These items display the current status of all monitored hardware devices/ components such as voltages, temperatures and all fans' speeds.

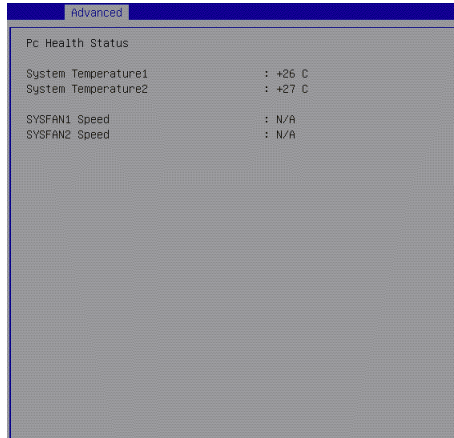

► **Smart Fan Configuration** *(the Carrier Board)*

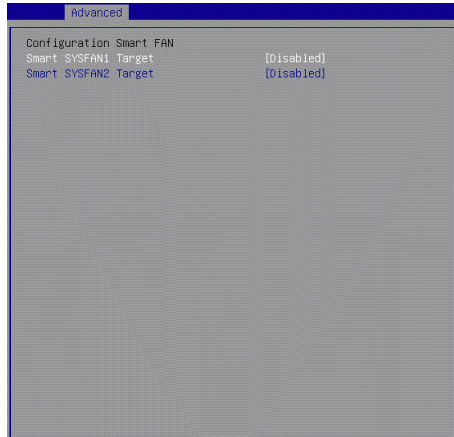

► **Smart SYSFAN1, SYSFAN2 Target**

These settings enable/disable the Smart Fan function. Smart Fan is an excellent feature which will adjust the CPU/system fan speed automatically depending on the current CPU/system temperature, avoiding the overheating to damage your system.

# Boot

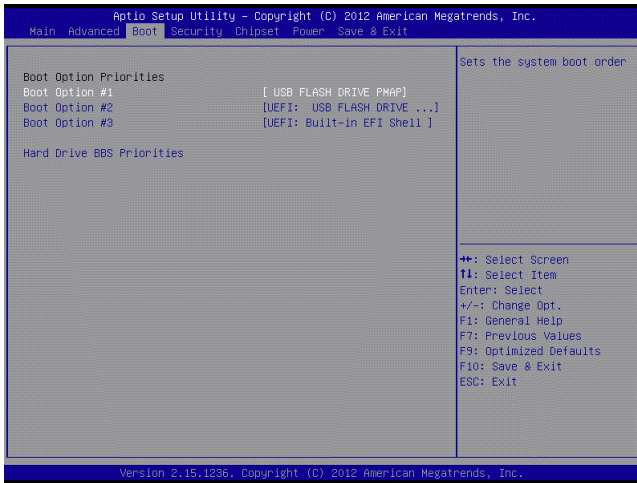

## ► Boot Option Priorities

This setting allows users to set the sequence of boot devices where BIOS attempts to load the disk operating system.

## ► Hard Drive BBS Priorities

This setting allows users to set the priority of the specified devices. First press <Enter> to enter the sub-menu. Then you may use the arrow keys ( ↑↓ ) to select the desired device, then press <+>, <-> or <PageUp>, <PageDown> key to move it up/down in the priority list.

# Security

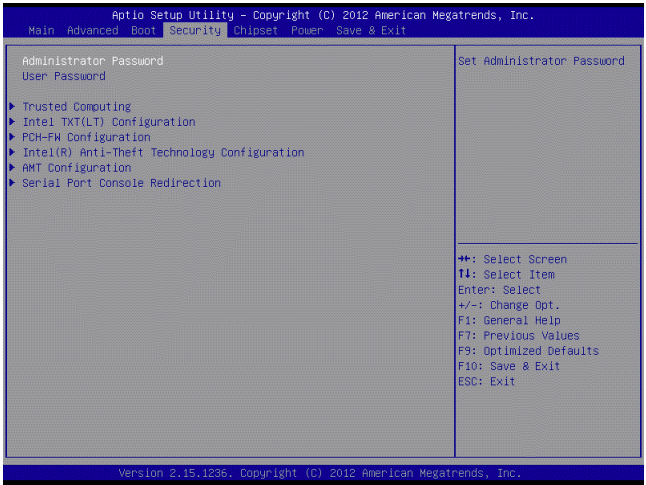

▶ **Administrator Password**

Administrator Password controls access to the BIOS Setup utility.

▶ **User Password**

User Password controls access to the system at boot and to the BIOS Setup utility.

▶ **Trusted Computing**

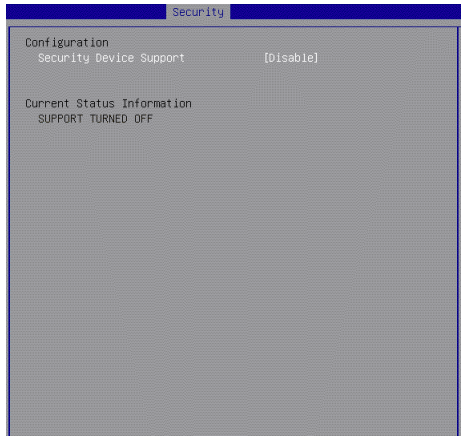

### ► Security Device Support

This setting enables/disables BIOS support for security device. When set to [Disable], the OS will not show security device. TCG EFI protocol and INT1A interface will not be available.

### ► Intel TXT(LT) Configuration

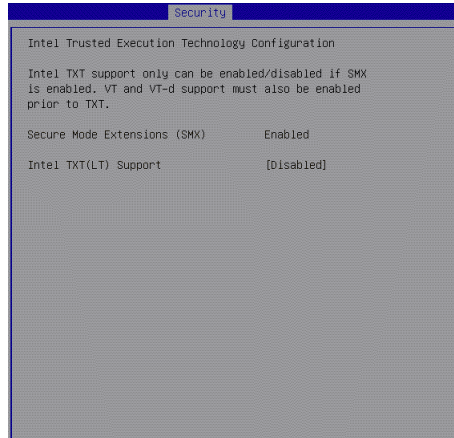

### ► Intel TXT(LT) Support

Intel TXT (Trusted Execution Technology) can only be enabled/disabled if SMX is enabled. VT and VT-d support must also be enabled prior to TXT.

### ► PCH-FW Configuration

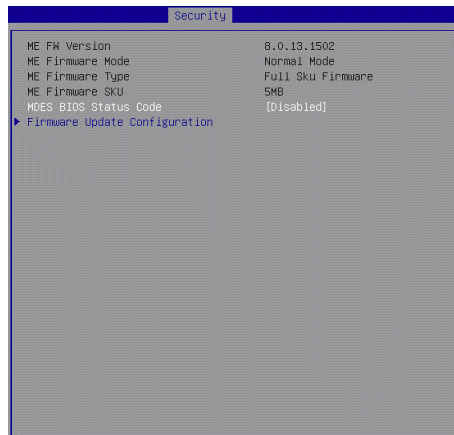

► **ME FW Version, ME Firmware Mode/ Type/ SKU**

These settings show the firmware information of the Intel ME (Management Engine).

► **MDES BIOS Status Code**

This setting enables/disables the MDES BIOS status code.

► **Firmware Update Configuration**



► **ME FW Image Re-Flash**

This setting enables/disables the ME FW image reflash.

► **Intel(R) Anti-Theft Technology Configuration**

Intel Anti-Theft Technology is hardware-based technology that can lock a lost or stolen system so that personal confidential information is protected and inaccessible by unauthorized users.

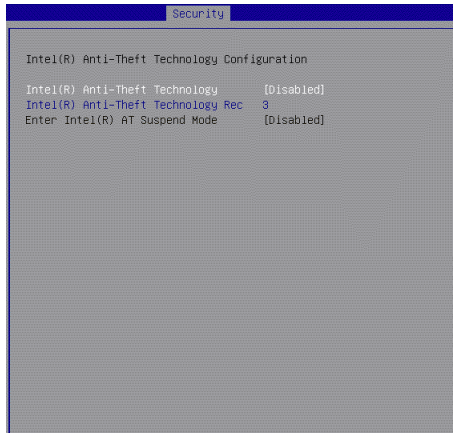



### ► AMT Configuration

Intel Active Management Technology (AMT) is hardware-based technology for remotely managing and securing PCs out-of-band.

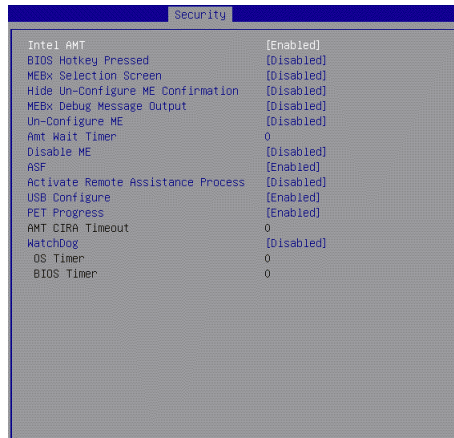

### ► Serial Port Console Redirection

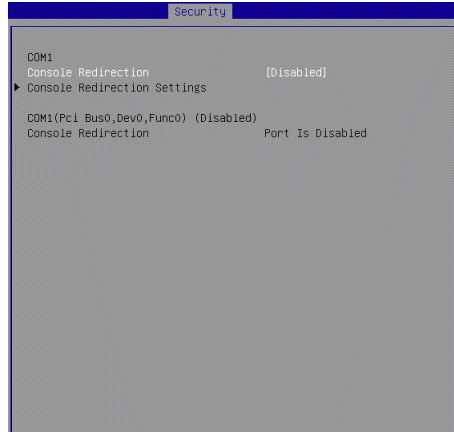

### ► Console Redirection

Console Redirection operates in host systems that do not have a monitor and keyboard attached. This setting enables/disables the operation of console redirection. When set to [Enabled], BIOS redirects and sends all contents that should be displayed on the screen to the serial COM port for display on the terminal screen. Besides, all data received from the serial port is interpreted as keystrokes from a local keyboard.

## ► Console Redirection Settings

COM1 Console Redirection Settings	
Terminal Type	[ANSI]
Bits per second	[115200]
Data Bits	[8]
Parity	[None]
Stop Bits	[1]
Flow Control	[None]
VT-UTF8 Combo Key Support	[Enabled]
Recorder Mode	[Disabled]
Resolution 100x31	[Disabled]
Legacy OS Redirection Resolution	[80x24]
Putty Keypad	[VT100]
Redirection After BIOS POST	[Always Enable]

### ► Terminal Type

To operate the system's console redirection, you need a terminal supporting ANSI terminal protocol and a RS-232 null modem cable connected between the host system and terminal(s). This setting specifies the type of terminal device for console redirection.

### ► Bits per second, Data Bits, Parity, Stop Bits

This setting specifies the transfer rate (bits per second, data bits, parity, stop bits) of Console Redirection.

### ► Flow Control

Flow control is the process of managing the rate of data transmission between two nodes. It's the process of adjusting the flow of data from one device to another to ensure that the receiving device can handle all of the incoming data. This is particularly important where the sending device is capable of sending data much faster than the receiving device can receive it.

### ► VT-UTF8 Combo Key Support

This setting enables/disables the VT-UTF8 combination key support for ANSI/VT100 terminals.

### ► Recorder Mode, Resolution 100x31

These settings enable/disable the recorder mode and the resolution 100x31.

### ► Legacy OS Redirection Resolution

This setting specifies the redirection resolution of legacy OS.

### ► Putty Keypad

PuTTY is a terminal emulator for Windows. This setting controls the numeric keypad for use in PuTTY.

### ► Redirection After BIOS POST

This setting determines whether or not to keep terminals' console redirection running after the BIOS POST has booted.

# Chipset

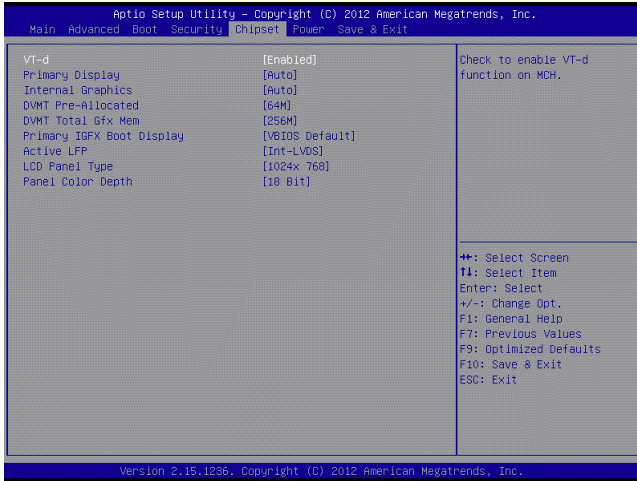

## ▶ VT-d

Intel Virtualization Technology for Directed I/O (Intel VT-d) provides the capability to ensure improved isolation of I/O resources for greater reliability, security, and availability.

## ▶ Primary Display

This setting specifies which is your primary graphics adapter.

## ▶ Internal Graphics

The field specifies the size of system memory allocated for video memory.

## ▶ DVMT Pre-Allocated

This setting defines the DVMT pre-allocated memory. Pre-allocated memory is the small amount of system memory made available at boot time by the system BIOS for video. Pre-allocated memory is also known as locked memory. This is because it is "locked" for video use only and as such, is invisible and unable to be used by the operating system.

## ▶ DVMT Total Gfx Mem

This setting specifies the memory size for DVMT.

## ▶ Primary IGFX Boot Display

Use the field to select the type of device you want to use as the display(s) of the system.

## ▶ Active LFP

This item is used for turning on/off LVDS support. (LVDS or No LVDS)

► **LCD Panel Type**

This setting allows you to set the resolution of the LCD display.

► **Panel Color Depth**

This item is used for setting the matching panel color depth.

# Power

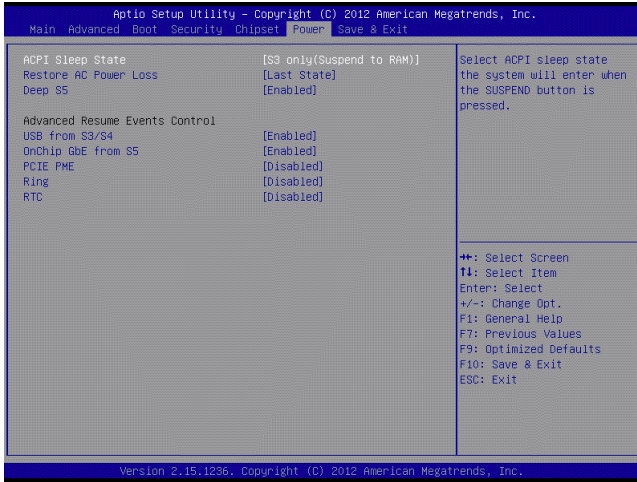

## ► ACPI Sleep State

This item specifies the power saving modes for ACPI function. If your operating system supports ACPI, you can choose to enter the Standby mode in S1 (POS) or S3 (STR) fashion through the setting of this field.

## ► Restore AC Power Loss

This setting specifies whether your system will reboot after a power failure or interrupt occurs. Available settings are:

[Power Off]	Leaves the computer in the power off state.
[Power On]	Leaves the computer in the power on state.
[Last State]	Restores the system to the previous status before power failure or interrupt occurred.

## ► Deep S5

The setting enables/disables the Deep S5 power saving mode. S5 is almost the same as G3 Mechanical Off, except that the PSU still supplies power, at a minimum, to the power button to allow return to S0. A full reboot is required. No previous content is retained. Other components may remain powered so the computer can "wake" on input from the keyboard, clock, modem, LAN, or USB device.

## \*\* Advanced Resume Events Control \*\*

### ► USB from S3/S4

The item allows the activity of the USB device to wake up the system from S3/S4 sleep state.

► **OnChip GbE from S5**

This field specifies whether the system will be awakened from power saving modes when activity or input signal of onchip LAN is detected.

► **PCIE PME**

This field specifies whether the system will be awakened from power saving modes when activity or input signal of onboard PCIE/PCI PME is detected.

► **Ring**

An input signal on the serial Ring Indicator (RI) line (in other words, an incoming call on the modem) awakens the system from a soft off state.

► **RTC**

When [Enabled], you can set the date and time at which the RTC (real-time clock) alarm awakens the system from suspend mode.

# Save & Exit

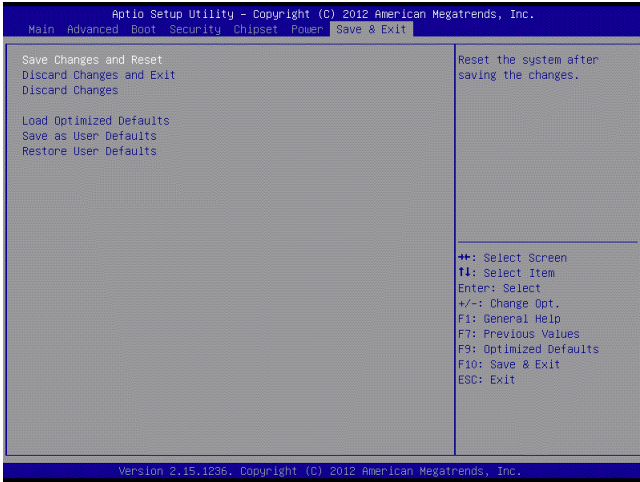

## ► Save Changes and Reset

Save changes to CMOS and reset the system.

## ► Discard Changes and Exit

Abandon all changes and exit the Setup Utility.

## ► Discard Changes

Abandon all changes.

## ► Load Optimized Defaults

Use this menu to load the default values set by the motherboard manufacturer specifically for optimal performance of the motherboard.

## ► Save as User Defaults

Save changes as the user's default profile.

## ► Restore User Defaults

Restore the user's default profile.

