

BPC-5070

Arestech

Fanless Embedded Box PC with 6th Generation Intel® Core™ i7/i5/i3 Processor & Multiple I/O



Features

- 6th Generation Intel® Core™ i7 Processor up to 3.4 GHz
- DDR4 1866 / 2133 MHz SO-DIMM up to 16 GB
- 2.5" SATA HDD & RAID 0/1
- 3 HDMI (Triple Display Output)
- -20 ~ 45°C Operating Temperature

Applications

- Embedded Digital Signage Control Systems
- Factory Automation Applications
- Image Processing (e.g. AOI)
- Transportation Management
- Machine Automation

→ Packing List

Description
1 x BPC-5070
1 x Driver CD
1 x Power Cord
1 x Startup Manual
1 x Power Adapter

→ Optional Items

Part No.	Description
i7-6700TE	Intel® 6th Gen Core™ i7-6700TE (8M Cache, 3.40 GHz)
i5-6500TE	Intel® 6th Gen Core™ i5-6500TE (6M Cache, 3.30 GHz)
i3-6100TE	Intel® 6th Gen Core™ i3-6100TE (4M Cache, 2.70 GHz)
G4400TE	Intel® Pentium™ G4400TE (3M Cache, 2.40 GHz)
G3900TE	Intel® Celeron™ G3900TE (2M Cache, 2.30 GHz)
AWD-WF001-00	Wi-Fi 802.11 b/g/n (1T1R) + 1 Antenna, Half-size
AWD-WF002-00	Wi-Fi 802.11 a/b/g/n/ac (1T1R) + 1 Antenna (Dual band), Half-size
AWD-WF003-00	Wi-Fi 802.11 a/b/g/n/ac/BT4.0 (2T2R) + 2 Antennas (Dual band), Half-size
AWD-3G002-00	3G (HSPA+) + 1 Antenna, Half-size with SIM socket

→ Ordering Information

Part No.	Description
BPC-5070-1A1	Intel® Core™ i LGA 1151 Processor, Q170, with 3 HDMI, 8 USB, 2 COM, RAID, 12-24 V DC, Fanless
BPC-5070-2A1	Intel® Core™ i LGA 1151 Processor, H110, with 2 HDMI, 8 USB, 2 COM, 12-24 V DC, Fanless

→ Dimensions

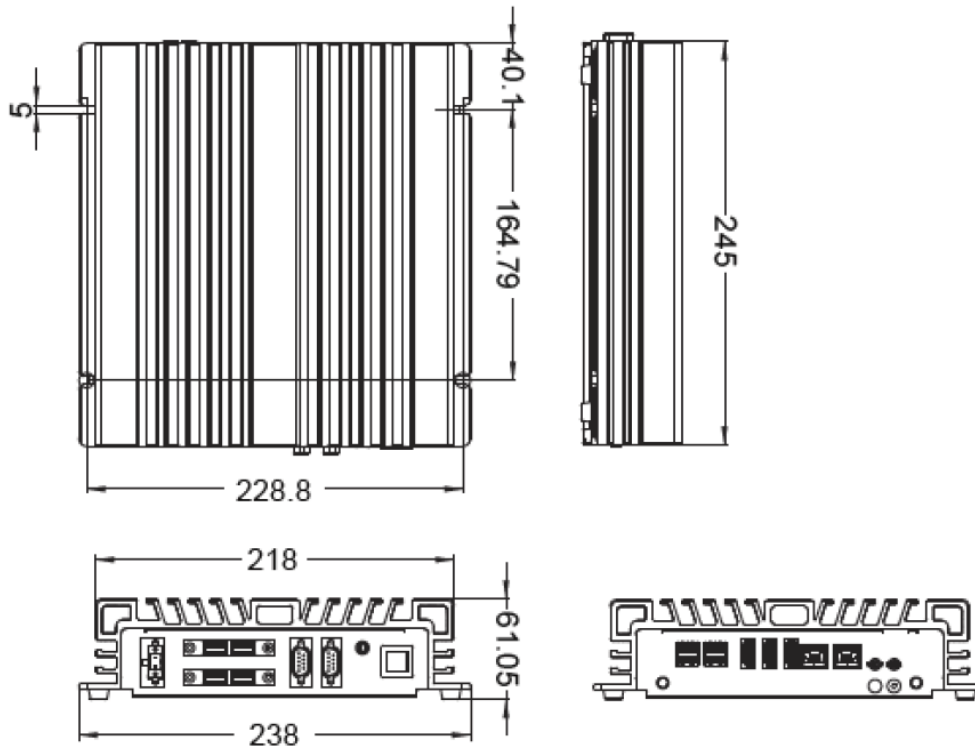

→ Specifications

Model		BPC-5070-1A1	BPC-5070-2A1
Processor System	CPU	Socket LGA 1151 for Intel®Core™ i7/i5/i3/Celeron (Skylake-S)	
	System Chipset	Intel Q170	Intel® H110
	BIOS	UEFI	
Memory	Technology	Dual-channel DDR4 1866/2133 MHz SDRAM	
	Max. Capacity	32 GB	
	Socket	2 (260-pin SO-DIMM)	
Display	Graphics Engine	Intel® Gen9 Graphics DX 11/12, OGL 4.3/4.4	
	HDMI	HDMI 1.4a up to 1080p, 1920 x 1200 @ 60 Hz max. resolution	
	Multi Display	Yes (Triple display), 3 HDMI Ports	Yes (Multi display), 2 HDMI Ports
I/O Interface	USB	8 (4 USB 3.0, 4 USB 2.0)	
	Serial Port	2 (RS-232/422/485)	
Ethernet	Controller	LAN1: 1 Intel® i210 LAN2: 1 I219LM	LAN1: 1 Intel® i210 LAN2: 1 I219V
Audio	Chipset	Realtek ALC887 High Definition Audio (HD)	
	Connectors	Line out, Mic in	
Storage	SATA	2 SATA III (6.0 Gb/s), (7 mm 2.5" HDD only)	
	RAID Function	RAID 0/1	N/A
Expansion	Mini PCIe	1 full-size, 1 half-size	1 half-size
Power	Power Type	AT / ATX	
	Power Supply Voltage	12-24 V DC input	
	Power Consumption (Typical)	0.8 A @ 12 V (9.5W)	
	Power Consumption (Max)	6.6 A @ 12 V (77.6 W)	
Environment	Operational	-20~45°C / 2.5" Extended Operation Temp. SSD	
	Non-operational	-20~75 °C and 60 °C @ 95% RH Non-condensing	
Certificate	Certification	CE, FCC Class A	
General	Dimensions (W x H x D)	238 x 61 x 245 mm (9.37" x 2.40" x 9.64")	
	Weight	3 kg (6.6 lb)	
	Operating System	Windows 7/8.1/10, WES7-E/P, WE8S, Ubuntu 14.04	