

# EmQ-v900

## QSEVEN™ CPU Module

### Quick Installation Guide

Version 1.1

<b>Form Factor</b> <i>QSEVEN CPU Module</i>	<b>CPU</b> <i>Soldered onboard VIA Nano™ U3500 processor</i>	<b>Chipset</b> <i>VIA VX900</i>
<b>Video</b> <i>Single Channel 24-bit LVDS</i>	<b>LAN</b> <i>Realtek RTL8111 Gigabit Ethernet</i>	<b>Audio</b> <i>HD Audio Interface</i>
<b>I/O</b> <i>USB/ SATA/ PClex1/ SDIO/ LPC</i>		

### ◆ Technical Support

If you have any technical difficulties, please consult the user's manual first at:  
<http://www.arbor.com.tw>

Please do not hesitate to call or e-mail our customer service when you still can not find out the answer.

<http://www.arbor.com.tw>

E-mail: [info@arbor.com.tw](mailto:info@arbor.com.tw)

FCC Class A

This device complies with Part 15 of the FCC Rules. Operation is subject to the following two conditions : (1) this device may not cause harmful interference, and (2) this device must accept any interference received, including interference that may cause undesired operation.



Copyright® All Rights Reserved.

4042090000110P

---

## Packing List

Before you begin installing your single board, please make sure that the following materials have been shipped:

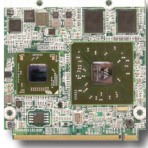

1 x EmQ-v900 QSEVEN™ CPU Module

---



1 x Driver CD

---



1 x Quick Installation Guide

---

## Ordering Information

EmQ-v900	VIA Nano™ U3500 1.0GHz QSEVEN™ CPU module
HS-V900-F1	Heat Spreader for EmQ-v900
HS-V900-C1	Cooler for EmQ-v900
PBQ-3000	Q <sub>SEVEN</sub> ™ EPIC carrier board
CBK-06-3000-00	Cable Kit 1 x USB cable 1 x USB2 cable 2 x COM port cables 1 x SATA cable 1 x SATA power cable

## Specifications

Form Factor	QSEVEN CPU Module
CPU	Soldered onboard VIA Nano™ U3500 at 1.0GHz processor
Chipset	VIA VX900
System Memory	Soldered onboard 1GB DDR3 SDRAM
VGA/ LCD Controller	Integrated Chronme9 DX9 controller
Ethernet controller	1 x Realtek 8111 PCIe Gigabit Ethernet
BIOS	AMI PnP Flash BIOS
Serial ATA	2 x Serial ATA ports w/ 300MB/s HDD transfer rate RAID 0, 1 supported
Universal Serial Bus	8 x USB 2.0 host ports, port1 may be configurable as USB 2.0 client port
Graphics Interface	LCD: Single Channel 24-bit LVDS DisplayPort or TMDS (Alternative)
Expansion Interface	2 x Gen. 2 PCIe x1 lanes LPC interface
Operation Temp.	-20°C ~ 70°C (-4°F ~ 158°F)
Watchdog Timer	1~ 255 levels Reset
Dimension (L x W)	70 x 70 mm (2.76" x 2.76")

---

## The Installation Paths of CD Driver

### Windows 2000 & XP

Driver	Path
CHIPSET	\EmQ-V900\CHIPSET\VIA_INF_V3.20A
LAN	\EmQ-V900\ETHERNETXP
VGA	\EmQ-V900\GRAPHICS\WinXP
Card Reader	\EmQ-V900\Others\VIA_MSP_CardReader_WindowsSoftwarePackage_V3.70A

### Windows 7

Driver	Path
CHIPSET	\EmQ-V900\CHIPSET\VIA_INF_V3.20A
LAN	\EmQ-V900\ETHERNET\Win7
VGA	\EmQ-V900\GRAPHICS\Win7
Card Reader	\EmQ-V900\Others\VIA_MSP_CardReader_WindowsSoftwarePackage_V3.70A

# Board Dimensions

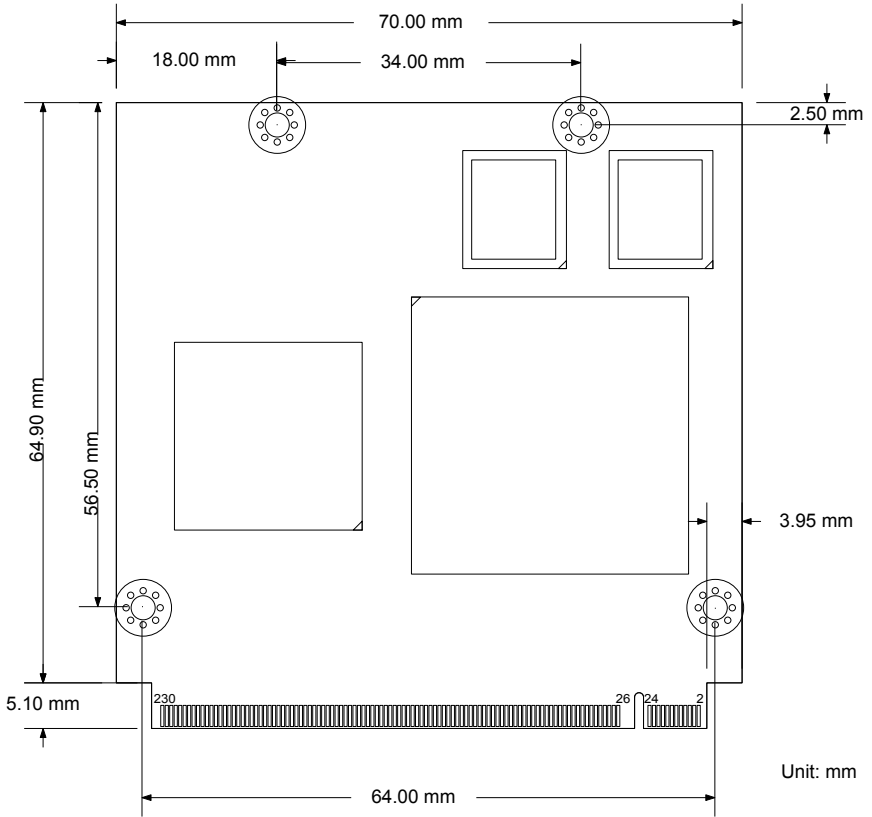

# Connector Pin Assignments

Pin	Signal	Pin	Signal
1	GND	2	GND
3	GBE_MDI3-	4	GBE_MDI2-
5	GBE_MDI3+	6	GBE_MDI2+
7	GBE_LINK100#	8	GBE_LINK1000#
9	GBE_MDI1-	10	GBE_MDI0-
11	GBE_MDI1+	12	GBE_MDI0+
13	GBE_LINK#	14	GBE_ACT#
15	GBE_CTREF	16	SUS_S5#
17	WAKE#	18	SUS_S3#
19	SUS_STAT#	20	PWRBTN#
21	SLP_BTN# (N/C)	22	LID_BTN#
23	GND	24	GND
	KEY		KEY
25	GND	26	PWGIN
27	BATLOW#	28	RSTBTN#
29	SATA0_TX+	30	SATA1_TX+
31	SATA0_TX-	32	SATA1_TX-
33	SATA_ACT#	34	GND
35	SATA0_RX+	36	SATA1_RX+
37	SATA0_RX-	38	SATA1_RX-
39	GND	40	GND
41	BIOS_DISABLE#	42	SDIO_CLK#
43	SDIO_CD#	44	SDIO_LED (N/C)
45	SDIO_CMD	46	SDIO_WP
47	SDIO_PWR#	48	SDIO_DAT1
49	SDIO_DAT0	50	SDIO_DAT3
51	SDIO_DAT2	52	SDIO_DAT5
53	SDIO_DAT4	54	SDIO_DAT7
55	SDIO_DAT6	56	RSVD
57	GND	58	GND
59	HDA_SYNC	60	SMB_CLK
61	HDA_RST#	62	SMB_DAT
63	HDA_BITCLK	64	SMB_ALERT# (N/C)

Pin	Signal	Pin	Signal
65	HDA_SDI	66	I2C_CLK
67	HDA_SDO	68	I2C_DAT
69	THRM#	70	WDTRIG#
71	THRMTRIP#	72	WDOUT (N/C)
73	GND	74	GND
75	USB_P7-	76	USB_P6-
77	USB_P7+	78	USB_P6+
79	USB_6_7_OC#	80	USB_4_5_OC#
81	USB_P5-	82	USB_P4-
83	USB_P5+	84	USB_P4+
85	USB_2_3_OC#	86	USB_0_1_OC#
87	USB_P3-	88	USB_P2-
89	USB_P3+	90	USB_P2+
91	USB_HOST_PRESEN#	92	USB_HC_SEL (N/C)
93	USB_P1-	94	USB_P0-
95	USB_P1+	96	USB_P0+
97	GND	98	GND
99	LVDS_A0+	100	LVDS_B0+ (N/C)
101	LVDS_A0-	102	LVDS_B0- (N/C)
103	LVDS_A1+	104	LVDS_B1+ (N/C)
105	LVDS_A1-	106	LVDS_B1- (N/C)
107	LVDS_A2+	108	LVDS_B2+ (N/C)
109	LVDS_A2-	110	LVDS_B2- (N/C)
111	LVDS_PPEN	112	LVDS_BPEN
113	LVDS_A3+	114	LVDS_B3+ (N/C)
115	LVDS_A3-	116	LVDS_B3- (N/C)
117	GND	118	GND
119	LVDS_A_CLK+	120	LVDS_B_CLK+ (N/C)
121	LVDS_A_CLK-	122	LVDS_B_CLK- (N/C)
123	LVDS_BLT_CTRL	124	RSVD
125	LVDS_DID_DAT	126	LVDS_BLC_DAT (N/C)
127	LVDS_DID_CLK	128	LVDS_BLC_CLK (N/C)
129	RSVD	130	RSVD

Pin	Signal	Pin	Signal
131	DP1TX3+	132	SDVO_INT+ (N/C)
133	DP1TX3-	134	SDVO_INT- (N/C)
135	GND	136	GND
137	DP1TX1+	138	DP1_AUX+
139	DP1TX1-	140	DP1_AUX-
141	GND	142	GND
143	DP1TX2+	144	SDVO_TVCLKIN+ (N/C)
145	DP1TX2-	146	SDVO_TVCLKIN- (N/C)
147	GND	148	GND
149	DP1TX0+	150	SDVO_CTRL_DAT (N/C)
151	DP1TX0-	152	SDVO_CTRL_CLK (N/C)
153	HDMI_HPD# (N/C)	154	DP_HPD#
155	PCIE_CLK_REF+	156	PCIE_WAKE#
157	PCIE_CLK_REF-	158	PCIE_RST#
159	GND	160	GND
161	PCIE3_TX+ (N/C)	162	PCIE3_RX+ (N/C)
163	PCIE3_TX- (N/C)	164	PCIE3_RX- (N/C)
165	GND	166	GND
167	PCIE2_TX+ (N/C)	168	PCIE2_RX+ (N/C)
169	PCIE2_TX- (N/C)	170	PCIE2_RX- (N/C)
171	EXCD0_PERST#	172	EXCD1_PERST#
173	PCIE1_TX+	174	PCIE1_RX+
175	PCIE1_TX-	176	PCIE1_RX-
177	EXCD0_CPPE# (N/C)	178	EXCD1_CPPE# (N/C)
179	PCIE0_TX+	180	PCIE0_RX+
181	PCIE0_TX-	182	PCIE0_RX-
183	GND	184	GND
185	LPC_AD0	186	LPC_AD1
187	LPC_AD2	188	LPC_AD3
189	LPC_CLK	190	LPC_FRAME#
191	SERIRQ	192	LPC_LDRQ#
193	VCC_RTC	194	SPKR
195	FAN_TACHOIN (N/C)	196	FAN_PWMOUT (N/C)

Pin	Signal	Pin	Signal
197	GND	198	GND
199	RSVD	200	RSVD
201	RSVD	202	RSVD
203	RSVD	204	MFG_NC4
205	VCC_5V_SB	206	VCC_5V_SB
207	MFG_NC0 (N/C)	208	MFG_NC2 (N/C)
209	MFG_NC1 (N/C)	210	MFG_NC3 (N/C)
211	VCC	212	VCC
213	VCC	214	VCC
215	VCC	216	VCC
217	VCC	218	VCC
219	VCC	220	VCC
221	VCC	222	VCC
223	VCC	224	VCC
225	VCC	226	VCC
227	VCC	228	VCC
229	VCC	230	VCC

